

An aerial photograph of a sports complex. In the center is a circular paved area with a large 'S' logo. To the left is a large green grassy field. To the right is a tennis court with a dark surface and green netting. At the bottom of the image is a large, multi-story building under construction, with a blue roof and extensive scaffolding. The surrounding area is lush with green trees and grass, with residential houses visible in the background under a blue sky with scattered clouds.

THE LOWTHER PAVILION

Venue Information Pack



Image Courtesy of Curfey&Taylor
Lytham Festival 2015

Contents

- Configurations & Capacity** **5**
- Standard Configuration.....5
- Thrust Configuration.....5
- Studio Configuration.....5
- Arena Configuration.....5
- Stage & Rear of House** **6**
- Dressing Room Availability.....6
- Stage Configuration.....6
- Flying Schedule.....8
- Drapery & Staging Equipment** **9**
- Standard Arrangement.....9
- Reserve Stock.....9
- Rostra & Risers.....9
- Stage Power.....9
- Lighting and Electrics** **12**
- Standard Rig.....12
- Control & Dimming.....12
- Reserve Stock.....12
- Rigging Capabilities.....12
- Sound** **15**
- Standard Rig.....15
- Microphone Stock.....15
- Speaker Stock.....15
- Reserve Stock.....15
- Notes.....15
- Audio Visual** **16**
- Standard Rig.....16
- Reserve Stock.....16
- Effects** **16**
- Show Operations** **17**
- Show Relay.....17
- Communications.....17
- FOH Position (Lighting & Sound).....17

Configurations & Capacity

Originally built in 1921 the Lowther Pavilion underwent a major refurbishment in 1982; comprising of a stage, auditorium with adaptable and removable seating, bar and studio space the Lowther Pavilion is capable of housing a wide variety of performance styles and events. A variety of arrangements are available for the venue and will be discussed at the time of contract negotiations. The 3 common arrangements are below (Full seating plans are available upon request), main entry to the auditorium is via a corridor leading in FOH left from the foyer or from the bar located on the front of house right. The venue has a standing capacity of 800 persons.

Standard Configuration

Floor Stalls - 144
 Raked Tier - 306
 Total - 450

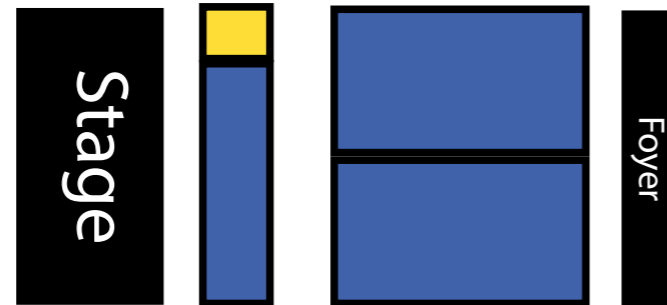

Thrust Configuration

Tiers - 126
 Floor - 74
 Total - 200

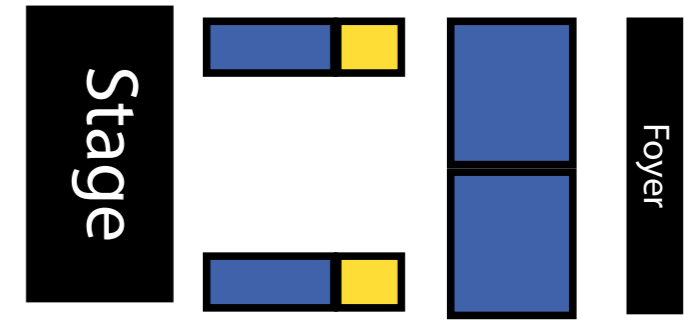

Studio Configuration

Configuration A

Tiers - 54
 Floor Stage -
 13m x 10m

Configuration B

Tiers - 90
 Floor Stage -
 10m x 10m

Configuration C

Tiers - 126
 Floor Stage -
 9m x 10m

Configuration D

Tiers - 306
 Floor Stage -
 7m x 10m



Flying Schedule

The Lowther Pavilion features a mixed flying system for lighting, scenic and drapery bars. Flying apparatus is mounted to RSJs fitted over the stage, unfortunately the pavilion does not have a fly tower limiting flying actions to fixed arrangements during performance. A combination of mechanical winches and hemp rope provide a variety of possibilities; all are controlled from an elevated floor accessed via a cat-ladder in the up stage right corner.

Bar ID	SWL	Configuration	Depth Xmm (From Rear)	Standard Usage
Set 17	100kg	3 Line Winch	250	Cyclorama
Set 16	100kg	5 Line Winch	450	Star Cloth/Rear Cloth
Set 15	100kg	3 Line Winch	1200	Lighting 4
Set 14	100kg	5 Line Winch	1700	Stage Legs (Tab 4)
Set 13	50kg	3 Line Hemp	2000	Border 3
Set 12	50kg	3 Line Hemp	2500	Open
Set 11	50kg	3 Line Hemp	2500	Open
Set 10	250kg	Qx25 Truss	3000	Lighting 3
Set 9	50kg	3 Line Hemp	3800	Stage Legs
Set 8	50kg	3 Line Hemp	4100	(Short Bar) Open
Set 7	100kg	5 Line Winch	4700	Mid Stage Tabs (Tab
Set 6	100kg	3 Line Winch	5000	Lighting 2
Set 5	100kg	3 Line Winch	5400	Tab 2
Set 4	100kg	5 Line Winch	5600	Tab 1 (Cloths/Gauzes)
Set 3	100kg	5 Line Winch	5800	Border 1
Set 2	100kg	3 Line Winch	6000	Lighting 1
Set 1	---	Fixed Drop	6500	Main Tabs (Motorised)
	350kg	Fixed Drop		Apron Truss
	750Kg	Fixed Drop		Advance Truss

Drapery & Staging Equipment

Standard Arrangement

Proscenium

- Front of House Tabs - Set 18 - Blue Velour
- Hard Masking/Border - Set 16 - Black Serge
- Midstage Tabs - Set 12 - Black Serge
- Border - Set 8 - Black Serge
- Stage Legs - Set 6 - Black Velour
- Border - Set 5 - Black Serge
- Stage Legs - Set 4 - Black Velour
- Rear Cloth - Set 2 - Black Serge LED Starcloth
- Cyclorama - Set 1 - White Cotton

Reserve Stock

- 2x Full Size Red velour tabs on golfball clips.
- 2x Full Size Blue velour Tabs on golfball clips.
- 1x Full stage white sharktooth gauze on ties.
- 9m T70 Track, split (on set 15 as standard)
- 9m T60 track, swipe (on set 14 as standard)

Runners are available for all our track.

Risers & Treadways

- 6x 1200mmx1800mmx500mm Risers
- 2x 1800mmx1500mm treadways (step up to 1500mm)
- 2x 500mm treads (top at 500mm)

Stage Power

- 1 63A, 3Phase USL (step down available)
- 1 32A, 3Phase DSL (step down available)
- 1 32A, 1Phase DSL (step down available)



Image Courtesy of Curffe&Taylor
Lytham Festival 2015

Lowther Pavilion Standard Lighting Rig

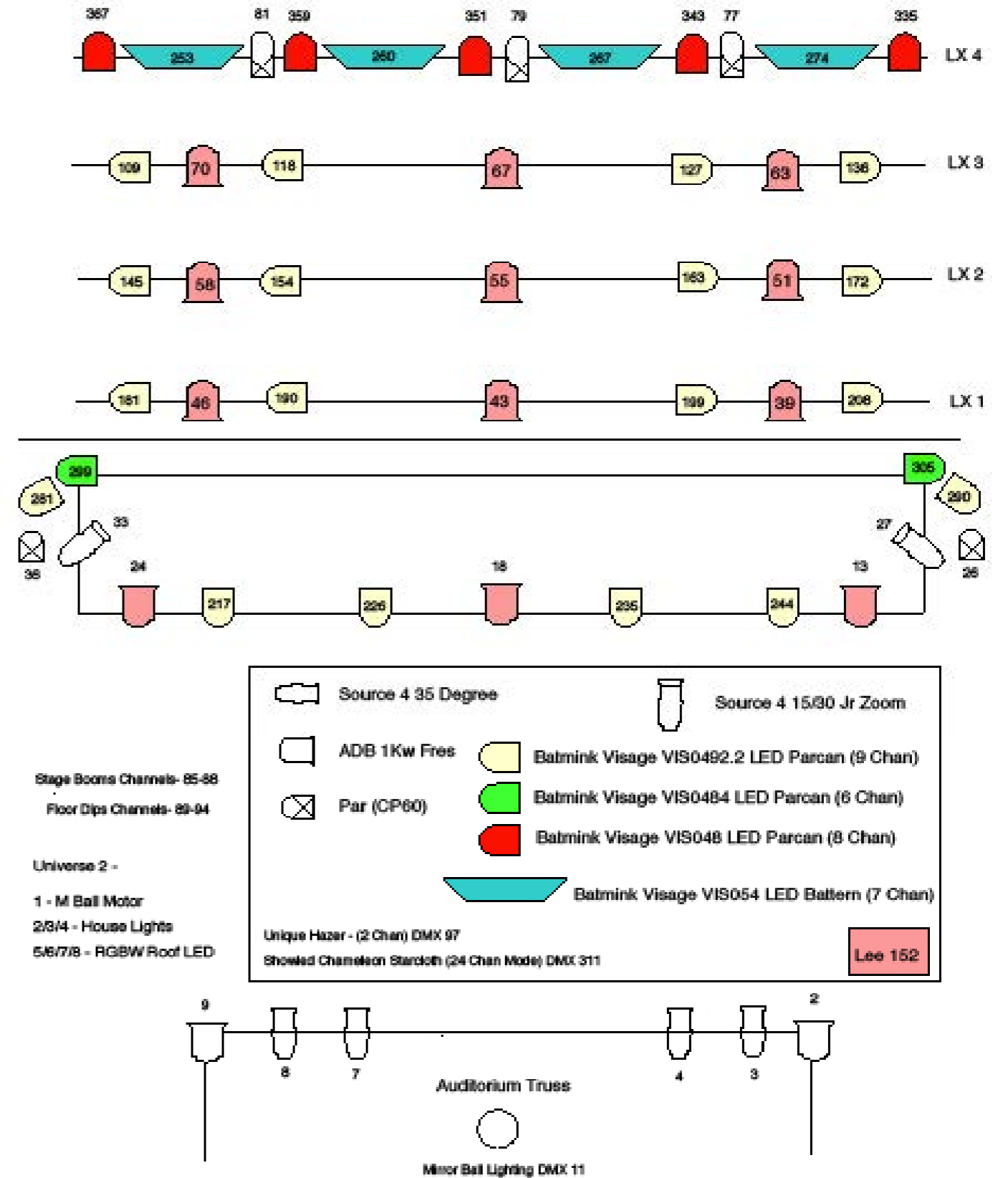

- | | |
|--|--|
| Batmink Visage VIS0492.2 LED Parcan (9 Chan) | R / G / B / W / A / UV / DIM / SHUTTER / COL MACRO |
| Batmink Visage VIS0484 LED Parcan (6 Chan) | R / G / B / W / A / UV |
| Batmink Visage VIS048 LED Parcan (8 Chan) | R / G / B / W / A / DIM / SHUTTER / COL MACRO |
| Batmink Visage VIS054 LED Battern (7 Chan) | COL MACRO / DIM / SHUTTER / R / G / B / W |

Lighting and Electrics

Control & Dimming

- Dimming - 4x Zero 88 Chilli Pro 96 - Totalling 96 Circuits (Dedicated Supply)
- Control - Avolites Tiger Touch (5 Universes available)
- House Control - Separate Dimmer Array
- 2 x Robert Juliat Tungsten Cricket

Reserve Stock

- 2 x ADB Fresnels
- 6 x Shortnose Floor Pars (60/62)
- 5 x Longnose Pars (95)

Additionally an LED starcloth is located to the rear of stage.

Distro & Dimming Capabilities

Data and 16A 1Phase installed to FOH,LX1,2,3 & 4 simultaneously.

Bar ID	Safe Working Load	Available Circuits
FOH Advance Truss	750kg (UDL)	12
FOH Box Truss	350kg (UDL)	24
LX 1	100kg	12
LX 2	100kg	12
LX 3 QX25 Truss	250kg	12
LX 4	100kg	12
DSL & DSR Boom		2 + 2 (Paired)
USR & USL Boom		2 + 2 (Paired)



Sound

Standard Rig

- Operations Desk - Allen & Heath QU32 (32 lines, 6 aux, 2 matrix)
- Playback Platform - Qlab 4, CD
- PA - Turbosound TCX15 (Pair), Brooke Sub Xpro2218 (Pair), Turbosound TCS20 (Centre), Turbosound TCX8 (Pair as delays 12 metres down the room), Turbosound TCX8 (Pair as delays 18 metres down the room)
- BSS Soundweb Proccess - Crown Amps

Microphone Stock

- Audio Technica, (Overheads and floats)
- Shure, (Band and vocal mics)
- Sennheiser, (Band and vocal mics)
- SE Electronics, (Band and vocal mics)
- Rode, (Band and vocal mics)
- Sontronics, (Band and vocal mics)
- Please email technical@lowtherpavilion.co.uk for a further break down.

Speaker Stock

- 8 x Brooke Passive Wedges (Xpro2110).

Extra

- Assorted Mic stands, DI's and cables.
- 4 ways of ethercom from control position to stage.
- 4 ways of MADI Coax from control position to stage.
- 48 way multi from control to stage. (36 sends, 12 returns).

Notes

Please note that changes to the standing PA rig should be discussed with the Technical staff prior to arrival. Companies with a touring PA should contact the theatre in advance to discuss arrangements. Please be aware that The Lowther Pavilion is situated in close proximity to residential areas.



Image Courtesy of Cuffe&Taylor
Lytham Festival 2015



Audio Visual

Standard Rig

- Projector - NEC NP3250 - 4500ANSI Lumen & cradle
- Signal Points - FOH, Control & DSL (Prompt)
- Cyclorama 9mx5m (rigged to rear stage wall as standard)

Reserve Stock

- 2x VGA Extensions - 15M
- 2x 75Ω BNC Extensions - 15M
- Variety of short jumpers and adaptors.

Effects

- Mirror Ball (600mm), including permanent LED pinspots.
- Unique 2.1 Hazer (Elevated SL)

Show Operations

Show Relay

Video and Audio show relay is available in various backstage locations, additional points and locations can be added with prior discussion.

- Video Show Relay - DSL (Prompt), includes opposite feed, general feed, backstage feed and FOH studio feed.
- Audio Show Relay - Independently manageable feed to all dressing rooms.

Communications

Communications points are distributed throughout the rear and front of house. The Lowther Pavilion has cans fitted at both control positions, both follow-spots and prompt as standard. Additional headsets and belt-packs are available upon request.

- Ring A - Lighting Control, Sound control, Follow-spot A, Follow-spot B.
- Ring B - Prompt Position, Fly Floor, Up Stage Right.
- Ring C - Auditorium Mix Position (Usable as a production ring)

FOH Position (Lighting & Sound)

Control Room - A Vandamme 36/12 multicore, 5 DMX universes (3 pin & 5pin), 4 ethercon lines, 4 MAD1 coax lines, 13A Power and Communications Points to DSL.

Lighting and sound control positions can be relocated to the auditorium floor upon request. It should be noted that this entails the removal of up to 12 auditorium seats from sale on the last row of the stalls, 12m from the stage appon.



Lowther Pavilion
and Gardens is a
charitable trust.
Charity Number:
1117054

All Enquiries:

operations@lowtherpavilion.co.uk

Lowther Pavilion
Lowther Terrace
Lytham St. Annes
FY8 5QQ

01253 794221



Image Courtesy of Cuffe&Taylor
Lytham Festival 2015